

Hydrosense HSCP

Conventional Water Detection Control Panel

Operation and Maintenance Manual

Man-1131 Issue 01 November 2009

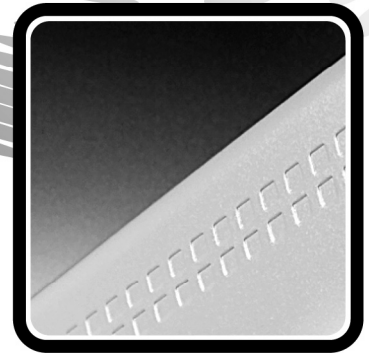

| Index | Page |
|--|-------------|
| 1. Introduction..... | 3 |
| 2. Safety and mounting | 3 |
| 3. Technical specification | 4 |
| 4. Control panel fascia | 5 |
| 5. Connecting to the circuit board..... | 6 |
| 6. Software revision number | 6 |
| 7. Wiring to Hydrowire and Hydrosense probes | 7 |
| 8. Sounder circuit wiring..... | 8 |
| 9. Connection to remote control terminals..... | 8 |
| 10. Aux 24V DC supply | 9 |
| 11. Connection to relay contacts | 9 |
| 12. Connection to Repeater panels | 9 |
| 13. Connection to Ancillary boards..... | 10 |
| 14. Panel operation..... | 11 |
| 15. Configuration options..... | 12 |
| 16. Watchdog reset switch..... | 14 |
| 17. Processor reset switch | 14 |
| 18. Internal indications – troubleshooting..... | 14 |
| 18.1 Mains fail..... | 14 |
| 18.2 Batt fail | 14 |
| 18.3 CPU fault | 15 |
| 18.4 Aux 24V fault | 15 |
| 18.5 Batt low..... | 15 |
| 18.6 Earth fault | 15 |
| 18.7 Sys fuse fault | 15 |
| 18.8 S1 fault and S2 fault | 15 |
| 18.9 Comms fault | 15 |
| 19. Power supply | 15 |
| 20. Maintenance | 16 |
| 21. Zone designation label..... | 16 |
| 22. Hydrowire commissioning details | 17 |
| 22.1 Installation | 17 |
| 22.2 Connection to Control Panel..... | 17 |
| 22.3 Remote Lamp Connection..... | 18 |
| 22.4 Testing..... | 18 |
| 22.5 General Checklist..... | 18 |
| 23. Hydrosense Probe Commissioning..... | 18 |

1. Introduction

The HYDROSENSE HSCP range consists of a series of conventional water detection control panels compatible with the Hydrowire system

The range consists of 2, 4 and 8 zone control panels.

All control panels have an integral, mains powered battery charger and power supply.

All control panels have voltage free relay contacts for alarm and local alarm which operate when water is detected. These can be used for local control and signalling.

2. Safety and mounting

Suppliers of articles for use at work are required under section 6 of the Health and Safety at Work act 1974 to ensure as reasonably as is practical that the article will be safe and without risk to health when properly used.

An article is not regarded as properly used if it is used 'without regard to any relevant information or advice' relating to its use made available by the supplier.

This product should be installed, commissioned and maintained by trained service personnel in accordance with the following:

- (i) IEE regulations for electrical equipment in buildings
- (ii) Codes of practice
- (iii) Statutory requirements
- (iv) Any instructions specifically advised by the manufacturer

According to the provisions of the Act you are therefore requested to take such steps as are necessary to ensure that you make any appropriate information about this product available to anyone concerned with its use.

This equipment is designed to be operated from 230V 50Hz mains supplies and is of class 1 construction. As such it **must** be connected to a protective earthing conductor in the fixed wiring of the installation and a readily accessible double pole disconnect device meeting the requirements of EN60950/IEC950 which disconnects live and neutral simultaneously shall be incorporated in the fixed wiring.

Switch disconnect devices such as MK Sentry 63A or similar are suitable for this.

Failure to ensure that all conductive accessible parts of this equipment are adequately bonded to the protective earth will render the equipment unsafe.

This control panel is designed for indoor use only and at temperatures between -5°C (+/- 3) and +40°C (+/- 2) and with a maximum relative humidity of 95%.

The IP rating for the enclosure is IP30.

Operation outside of these limits may render the equipment unsafe.

Mounting

The control panel should be mounted on a dry, flat surface, at eye height to the display and in a level position such that the enclosure is not distorted.

Screws or bolts of a minimum of 5mm diameter must be used to mount the enclosure in all three mounting positions.

It should be positioned in an accessible position as agreed with the end user.

Suitable fixings should be used at all fixing points such that the control panel is securely mounted and is not liable to move once fixed.

The control panel should not be mounted in another enclosure or near sources of excessive heat.

Cables should be connected using suitable cable glands fitted to the knockouts provided. If additional cable entry points are required, all swarf and debris caused by drilling of additional cable entries must be cleared before power is applied to the panel.

3. Technical specification

Table 1 - Electrical specifications

| | | |
|---|---|--|
| Mains supply | 230V AC +10% - 15% (100 Watts maximum) | |
| Mains supply fuse | 1.6Amp (F1.6A L250V) | <i>Replace only with similar type</i> |
| Power supply rating | 3 Amps total including battery charge 28V +/- 2V | |
| Maximum ripple current | 1.5 Volts | |
| Output voltage | 18.5 to 29V DC +/- 2% | |
| I _{max a} | 400 milliamps | |
| I _{max b} | 2.3 Amps | |
| I _{min} | 0.065A | |
| Battery type (Yuasa NP) | Two 12 Volt sealed lead acid (7Ah maximum) | <i>See table 2 for capacities</i> |
| Battery charge voltage | 27.6VDC nominal (temperature compensated) | <i>See table 3</i> |
| Battery charge current | 0.7A maximum | |
| Battery lead fuse | 20mm, 3.15A glass | <i>Replace only with the same type</i> |
| Battery high impedance warning (R _{imax}) | 1.35 ohms max | |
| Low battery voltage indication | 21V +/- 2% | |
| Low battery shut off voltage | 18.5V +/- 2% | |
| Maximum current draw from batteries | 3 Amps | <i>With main power source disconnected</i> |
| ROV output | Fused at with electronic fuse | |
| Dedicated sounder outputs | 24V Fused at 500mA with electronic fuse | <i>1.6 Amp total load over <u>all</u> circuits</i> |
| Fault relay contact rating | 30VDC 1A Amp maximum for each | <i>Maximum ratings not to be exceeded</i> |
| Alarm relay contact rating | 30VDC 1A Amp maximum for each | <i>Maximum ratings not to be exceeded</i> |
| Local alarm relay contact rating | 30VDC 1A Amp maximum for each | <i>Maximum ratings not to be exceeded</i> |
| Zone quiescent current | 1.6mA maximum | <i>See table 4 for detector types</i> |
| Terminal capacity | 0.5mm ² to 2.5mm ² solid or stranded wire | |
| Number of detectors per zone | > 20 | <i>Dependent on type</i> |
| Number of sounders per circuit | Dependent on type and current consumption | <i>See table 6 for sounder types</i> |
| Detection circuit end of line | 6K8 5% ½ Watt resistor | <i>Supplied in terminals</i> |
| Sounder circuit end of line | 10K 5% ¼ Watt resistor | <i>Supplied in terminals</i> |
| No. of detection circuits | (see table 2 for number of zones for each model) | <i>Dependent on model</i> |
| No. of sounder outputs | 2 (plus one per zone on T models) | |
| SIL, AL, FLT, RST inputs | Switched -ve, max resistance 100 Ohms | |
| Zone normal threshold | 8K ohm TO 1K ohm | |
| Detector alarm threshold | 999 ohms to 400 ohms | |
| Short circuit threshold | 99 ohms to 0 ohms | |

Table 2 - Standby battery capacity required for fully loaded system

| Panel model | 24 hours standby | 48 hours standby | 72 hours standby | Standby current | Max panel alarm current |
|--------------------|------------------|------------------|------------------|-----------------|-------------------------|
| HSCP-S-2 (2 Zones) | 3Ah | 4.6Ah | 6.2Ah | 0.065 | 0.10A |
| HSCP-S-4 (4 Zones) | 3.3Ah | 5.1Ah | 6.9Ah | 0.075 | 0.21A |
| HSCP-S-8 (8 Zones) | 3.75Ah | 5.95Ah | 8.2Ah | 0.093A | 0.55A |

Table 3 - Battery charge voltage versus temperature

| Temperature °C | Battery charge voltage |
|----------------|------------------------|
| 0 | 29.2 |
| 10 | 28.56 |
| 20 | 27.99 |
| 30 | 27.55 |
| 40 | 27.13 |

Table 4 - Compatible sounders

| Model | Type | Manufacturer | Comments |
|-----------------|------------------|--------------|----------|
| BANSHEE | ELECTRONIC | VIMPEX | |
| WAFER | ELECTRONIC | VIMPEX | |
| FIRECRYER RANGE | ELECTRONIC VOICE | VIMPEX | |
| KOBISHI | MOTORISED | VIMPEX | |
| | | | |
| | | | |
| | | | |

4. Control panel fascia

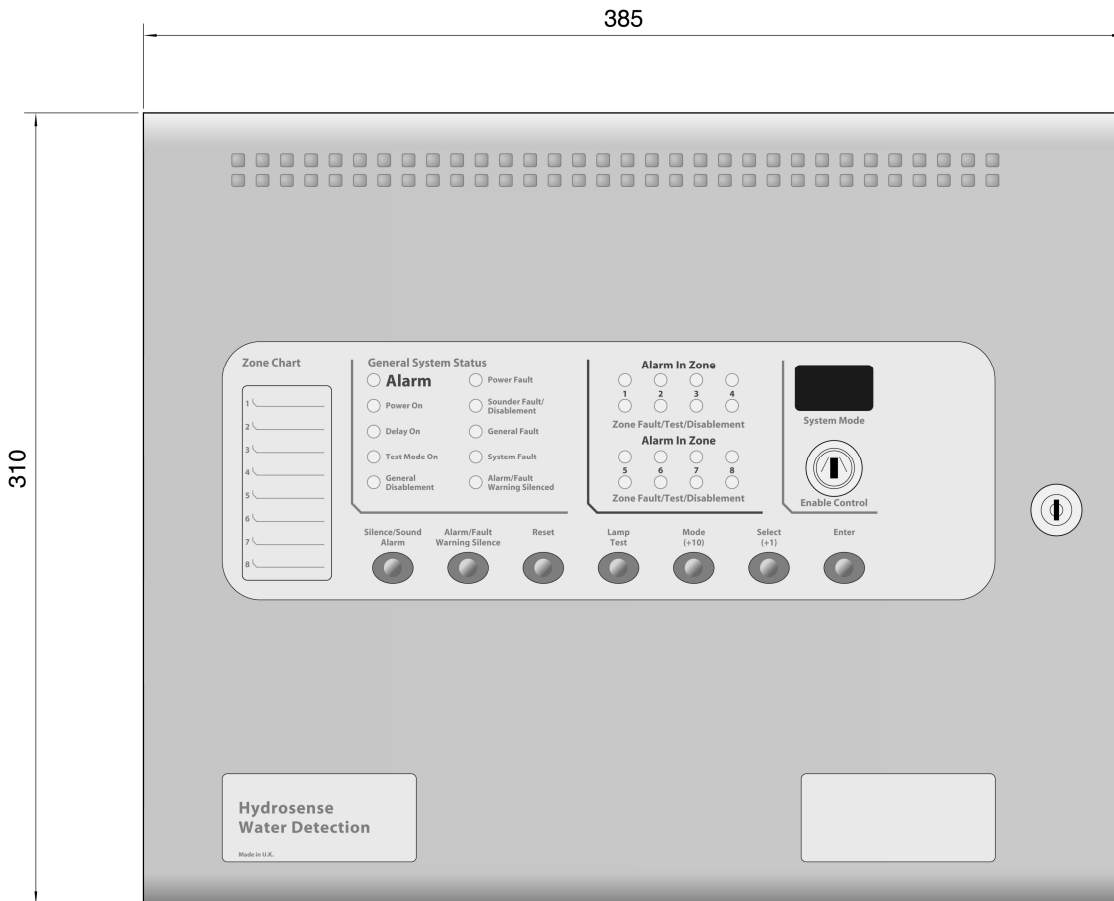

In addition to standard silence and reset controls, two, seven segment, LED displays and MODE, SELECT and ENTER buttons are provided to allow easy entry and storage of codes to configure the control panel to suit the requirements of the installation.

Removing the fascia

Before the fascia can be removed it will be necessary to unplug the three way terminal block on the left hand side of the PCB.

The fascia of the control panel is held in place by countersunk screws. Undo the two screws and lift the fascia gently away from the box towards you.

With the fascia removed there is much more room inside the panel for making off and dressing cables.

When cabling work is complete the fascia can be re-fitted with the two countersunk screws and the red, green/yellow and black wires re-connected to the three way terminal block.

It is most important that the polarity of the red and black wires is observed as wrong connection of these will damage the control panel.

5. Connecting to the circuit board

All connections for field wiring are to a single row of terminals along the top of the circuit board. The connections for the power cables are to a pluggable terminal block which may be pulled off of the board to remove the plate/PCB assembly. Remove this pluggable terminal only with mains power off.

The resistance of any core of any cable must not exceed 25 ohms. The shield of the cable must be bonded securely to the enclosure via a metal gland.

Wiring should enter the enclosure at the top of the panel using the knockouts provided and be formed tidily to the appropriate terminals leaving only enough wire to ensure that there is no strain on the PCB.

Terminals are capable of accepting wires of up to 2.5mm².

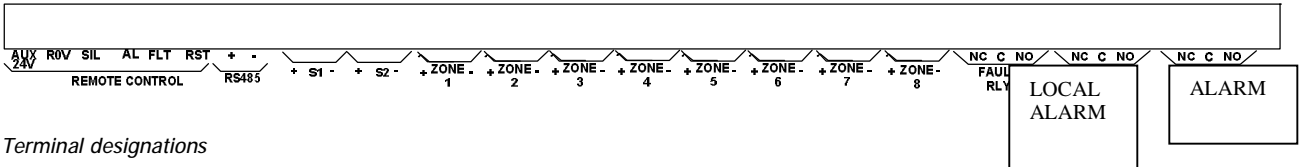

Terminal designations

Wiring must not go across the front of the circuit board plate or between the plate and the circuit board. If cable entries need to be in positions other than at the knockouts provided, wiring must be fed behind and well away from the surface of the circuit board.

The space at the bottom of the enclosure is largely occupied by the standby batteries so this must be borne in mind when considering cable entries.

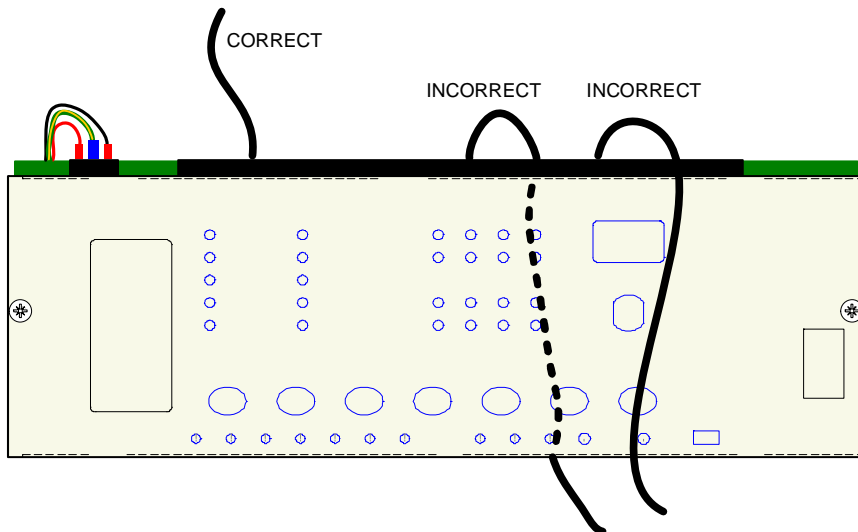

6. Software revision number

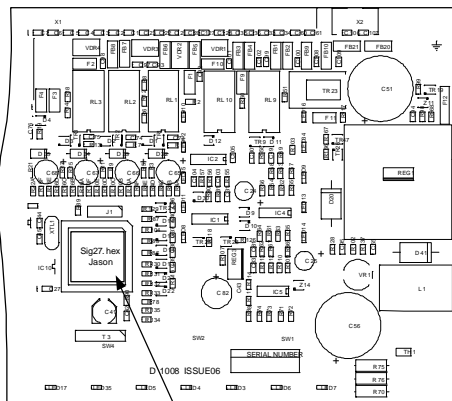

SOFTWARE VERSION LABEL

New features may be added to HYDROSENSE HSCP alarm control panels from time to time and when this is done the operating software of the unit is updated. The software revision can be located on the main processor by removing the plate holding the PCB from the enclosure and turning it over. The software version will have a number such as "Sig27.hex" and it is this number which will determine which features the panel has installed and its compatibility with HYDROSENSE HSCP ancillary board, sounders boards, repeaters etc.

7. Wiring to Hydrowire and Hydrosense probes

The detection zones provide a nominal 24V DC to power Hydrosense detectors and Hydrowire. The wiring, including the Hydrowire, is monitored with the use of the End of Line Plug. When using Hydrowire the 6K8 EOL Resistor supplied in the terminals of the detection zone being used can be discarded. Any unused zones must have the 6K8 resistor in place.

When using Probes the 6K8 Resistor must be placed across the terminal wiring as illustrated in the diagram below.

Detection zone circuits must be wired as a single, radial circuit with no spurs or T junctions to enable the monitoring circuit to work correctly.

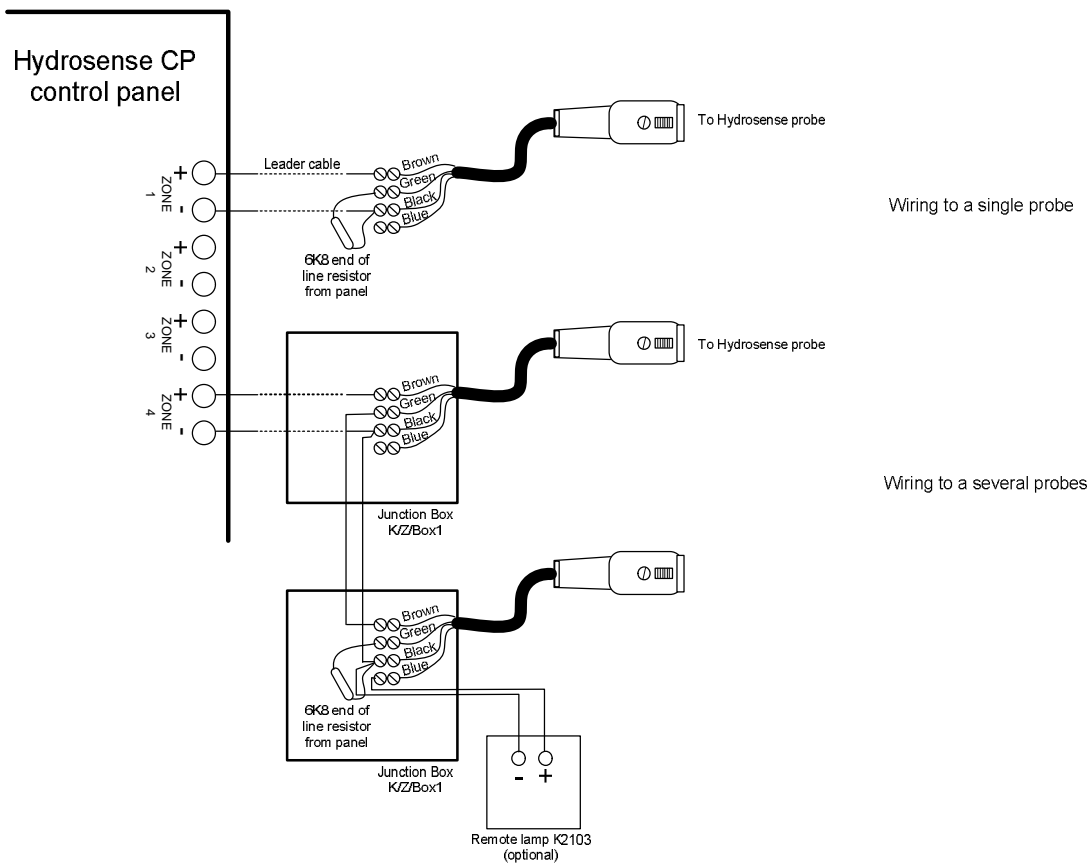
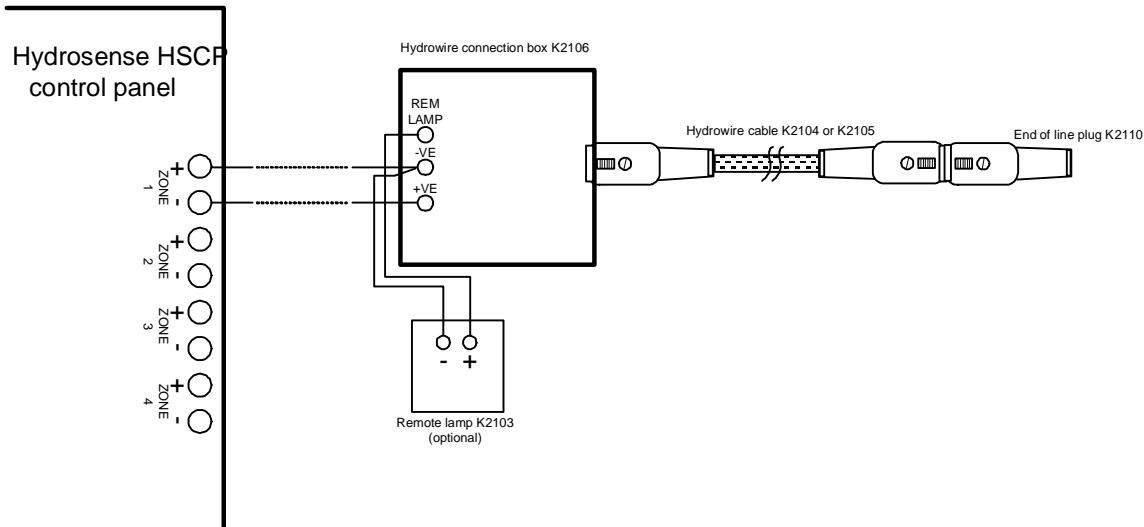

8. Sounder circuit wiring

All sounders must be of the polarised type. If non-polarised sounders are used the control panel will permanently show a fault condition. See table 6 on page 7 for a list of compatible sounder types. Sounder circuits are monitored for open and short circuit faults by placing a 10K end of line monitoring resistor across the last device on the circuit.

Sounder circuits must be wired as a single, radial circuit with no spurs or T junctions to enable the monitoring circuit to work correctly.

A maximum of 1.6 Amps is available for powering sounders with a maximum load of 0.41 Amps on any one circuit.

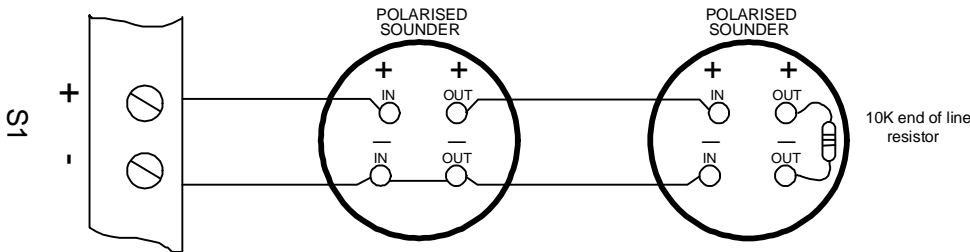

Figure 6.- Sounder circuit wiring

9. Connection to remote control terminals

Some functions of the control panel can be controlled externally from the panel if required. These are abbreviated at the terminals block as follows:

- a) Remote 0 V supply - ROV
- b) Silence Alarm – SIL
- c) Sound Alarm – AL
- d) Fault – FLT
- e) Reset – RST

To activate these inputs, the remote 0 Volt (ROV) supply must be connected to the input via a normally open switch or contact and via a resistance of no greater than 100 ohms. All of the remote control inputs are non-latching.

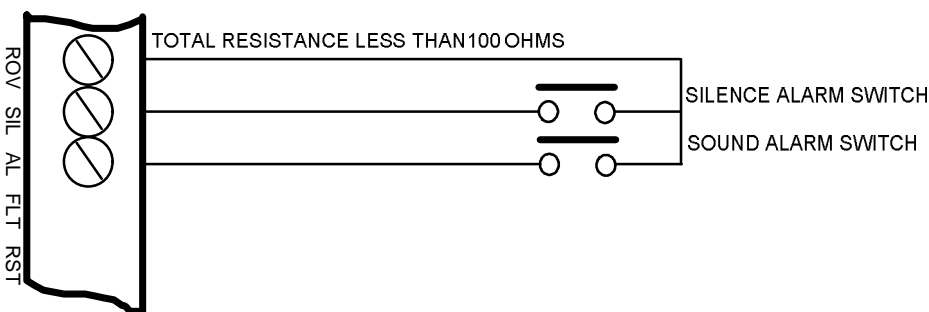

Figure 7- Example connections to remote control inputs

10. Aux 24V DC supply

An auxiliary 24V DC supply is provided to enable local signalling or control of ancillary systems such as graphical mimic displays.

The terminals for the Aux 24V supply are labelled Aux 24V and ROV. The ROV terminal is the negative terminal and is the same terminal that should be used to switch the remote control terminals.

It is possible to make the ROV terminal pulsing so that by connecting it to the AL terminal via a remote, volt free contact, it can be used to pulse the dedicated sounder circuits in response to a signal from another system for example to give an alert. See programming code 24.

The supply is fitted with an electronic self resetting fuse to protect the control panel's 24V supply in the event of a wiring fault.

Any standing load on the Aux 24V supply must be taken into account when calculating battery standby times as standby time will be significantly affected by even modest standing loads. It is recommended that the Aux24V output is **not** used to power standing loads and not used to supply loads of greater than 300 milliamps

Where the Aux 24V supply is used to power electromechanical devices such as relays it is imperative that a suppression diode is fitted across the coil of the electromechanical device to prevent the generation of high voltage transients back to the control panels power supply.

11. Connection to relay contacts

Volt free changeover relay contacts are provided for local control and signalling if required. These contacts are rated for switching signalling circuits only and the maximum ratings listed in table 1 on page 5 should not be exceeded under any circumstances.

Fault relay

The fault relay is normally energised and will de-energise upon any fault condition including total loss of power.

Local alarm relay

The local alarm relay will energise upon activation of an alarm condition on any of the zones or pressing of the sound alarm button on the front panel. The relay will remain activated until the alarm is silenced or the panel is reset. This relay will not operate upon activation of the remote AL input or when an alarm condition is triggered on a zone that is in test mode.

Alarm relay

The alarm relay will energise upon activation of an alarm condition on any of the zones. The relay will remain activated until the control panel is reset. This relay will *NOT* operate upon activation of the remote AL input. Individual zones can be configured not to operate the Alarm relay by setting configuration options E1 to E8.

12. Connection to Repeater panels

Repeater panels connect via a 2 core cable to the terminals marked RS485 + and – on the HYDROSENSE HSCP main control panel PCB. Up to 7 repeaters may be connected and each repeater has terminals for the incoming cables and outgoing cables. All except the last ancillary board, sounder board or repeater panel connected to the cable must have the jumper links J2 removed.

Set the repeater address using the DIP switch (SW7); ensure no two repeaters share the same address.

Apply power to main panel first and then all repeater panels. Turn on the Enable Control keyswitch and set the Write Enable switch to on then briefly press the PROCESSOR RESET button on the main panel. Wait for a few seconds and the main panel will show the addresses of the repeaters that were found on the display for instance r1 indicates that a repeater at address 1 has been found.

Turn the write enable switch off, then on again and then press the ENTER button to accept each repeater that has been found. When all repeaters have been added, set the main panel Write Enable switch to off. Press the Watchdog reset switch on the main panel.

All repeaters are now configured and the main control panel will report a fault if any repeaters that have been accepted become faulty or go off line.

For full details of commissioning procedures for repeaters see the HYDROSENSE HSCP Repeater Operation and maintenance manual.

13. Connection to Ancillary boards

Ancillary boards connect via a 2 core cable to the terminals marked RS485 + and – on the HYDROSENSE HSCP main control panel PCB. Up to 7 Ancillary boards may be connected and each board has terminals for the incoming cables and outgoing cables. All except the last ancillary board, sounder board or repeater panel connected to the cable must have the jumper links J2 removed.

Set the ancillary board address using the DIP switch (SW7); ensure no two ancillary boards share the same address.

Apply power to main panel and all ancillary boards then briefly press the PROCESSOR RESET button on the main panel, wait for a few seconds and the main panel will show the addresses of the ancillary boards that were found on the display for instance 01 indicates that an ancillary board at address 1 has been found. Press the ENTER button to accept each ancillary board that has been found.

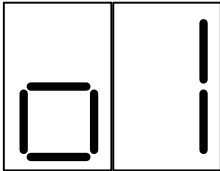

The control panel will report a fault if any ancillary boards that have been accepted become faulty or go off line.

For full details of commissioning procedures for ancillary boards see the HYDROSENSE HSCP Ancillary board Operation and maintenance manual.

14. Panel operation

14.1 Normal condition

Under normal conditions, control panels will have only the green, *Power On* LED lit.

14.2 Alarm condition

Upon receipt of an alarm condition by activation of a water detector, the *Common Alarm* indicator will light and the zonal *Alarm* indicators will flash at around 2Hz.

The alarm and local alarm relays will also operate and signal any systems to which they are connected.

Any sounders connected to the sounder circuits will operate in common, zonal or 2-stage mode as selected by configuration options 10 to 12 (see table 8).

14.3 Silence/sound alarms

The *Silence/Sound alarm* button can only be operated at access level two which means that the *Enable Control* key must be inserted.

To silence the sounders, insert the Enable Control key and press the Silence/Sound alarm button.

When the sounders have been silenced, the Zone Alarm LEDs will change from flashing to a steady state.

Pressing the *Silence/Sound alarm* whilst the control panel is in this silenced condition, will cause the sounders to operate again.

The sounders can be toggled on and off with the *Silence/Sound alarm* button as required.

14.4 Reset

To reset the panel, insert the Enable key then press the Reset button.

14.5 Zone fault

Removal of a water detector or a fault on any of the zone wiring will cause the *Fault* LED and *Zone Fault* LEDs to light indicating the zone in which the fault has occurred.

14.6 Sounder fault

A fault on the wiring to sounder circuits will cause the *Fault* and *Sounder Fault* LEDs to light indicating a fault on the wiring to the sounder circuits.

14.7 Power fault

Failure of the mains power, disconnection of the standby battery or high impedance in the charging circuit will cause the *Fault* and *Power Fault* LEDs to light indicating an abnormality in the power supply to the control panel.

14.8 System fault

The *System Fault* LED will light if the configuration memory has not been set or has become corrupt.

14.9 Lamp test

All LED indicators can be tested at any time by pressing the *Lamp Test* button. The *Enable Control* key does not need to be inserted to test the indicators.

The buzzer can be silenced at any time by pressing the *Buzzer Silence* button. The enable key does not need to be inserted to silence the buzzer.

14.10 Disablements

It is possible to disable parts of the system. This may be required if there are works going on in a building which may cause the water detection system to operate in error.

14.10.1 Disable zones

To disable zones, the *Enable Control* key should be inserted and the mode button pressed until "d" appears in the first of the two seven segment LED displays. The *Select* button should then be pressed to select the number of the zone which is to be disabled in the second of the two seven segment displays. Once the desired zone is displayed, the enter button should be pressed to confirm the disablement.

The *Disable* LED will light and the *Zone Fault* LED will light for each disabled zone.

14.10.2 Disable sounders

To disable sounder outputs, press the mode button to select "db" on the seven segment display. Pressing enter will disable all sounders and cause the *Disable* and *Sounder Fault* LEDs to light.

14.10.3 Activate delays

To activate delays on zones as set in configuration options 31 to 48, press the mode button until Ad appears on the seven segment LED display. When the enter button is pressed any zones that are set as delayed will have their alarm outputs delayed by the time set in configuration options 00 to 09.

14.10.4 Disable fault contact

The fault relay can be disabled by selecting configuration option 22.

14.11 Test mode

The HYDROSENSE HSCP range of panels enable the system to be tested single handed by using a test mode. When in test mode, activation of a water detector will be automatically reset (after drying the detector) within a few seconds to eliminate the need to return to the control panel to reset after every activation.

Test mode is entered in a similar way to disablements. With the *Enable Control* key inserted, press the *Mode* button until "t" appears in the first of the seven segment displays. Then press the *Select* button until the required zone number appears. Pressing the *Enter* button will cause the *Test* and *Zone Fault* LEDs to illuminate indicating the zones which are in test mode.

Disablements and zone tests are cleared by repeating the sequence that is used to select them, i.e. the "db" function (for example) toggles between sounders disabled and sounders enabled.

15. Configuration options

The HYDROSENSE HSCP range of control panels has many configuration options which can be set at the time of commissioning to suit the requirements of the installation. These options are normally set once and will rarely need to change. The configuration options are only available at access level 3.

To access level 3, CAREFULLY slide the Write Enable switch (located behind the aperture in the panel plate) to the right position using a small screwdriver or similar. When the panel is at access level 3, the buzzer will "pip" three times every few seconds as an indication that it is at this access level.

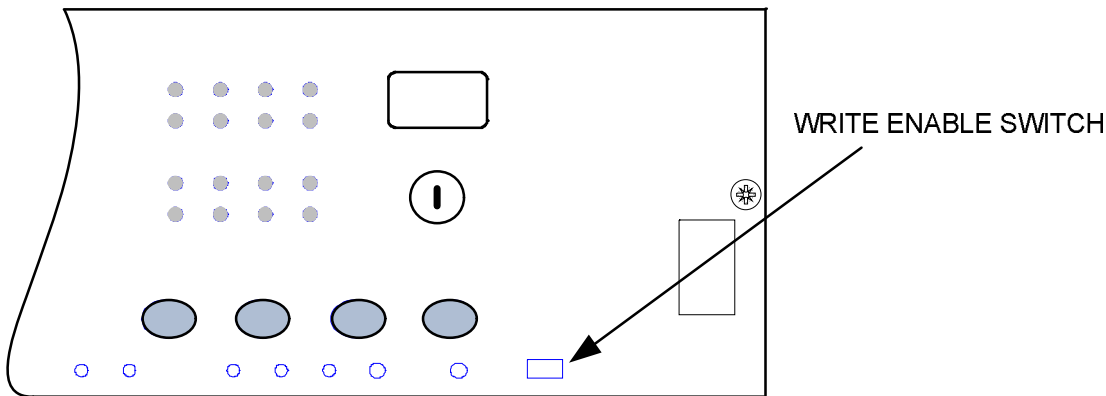

Figure 8 – Access level 3 (Write enable) enable switch location

Configuration options are simple to enter using the codes in table 8 below. When the control panel is at access level 3, the sub-text of the *Mode* and *Select* buttons is used to enter a number using tens (+10) and units (+1).

When the required code number is displayed, pressing the enter button will cause the dot on the units, seven segment display to flash. This indicates that a configuration option has been set.

To review which configuration options have been set previously, simply scroll through numbers 1 to 99, A1 to A8, C1 to C8 and E1 to E8 and those with a flashing dot indicate which options have been set.

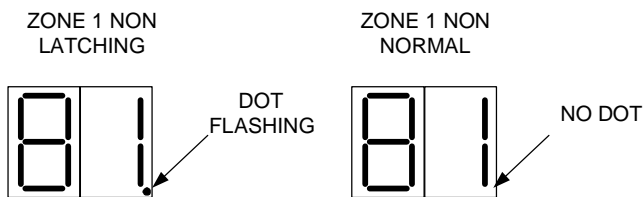

Figure 9 – Example display showing option set and not set.

Table 8 – Configuration codes

| CODE | FUNCTION | COMMENTS |
|------|--|---|
| 00 | SOUNDER DELAY TIME = 30 SECONDS | Sets the time delay before sounders operate in combination with configuration codes 31 to 48 and access level 2 function AD. |
| 01 | SOUNDER DELAY TIME = 1 MINUTE | |
| 02 | SOUNDER DELAY TIME = 2 MINUTES | |
| 03 | SOUNDER DELAY TIME = 3 MINUTES | |
| 04 | SOUNDER DELAY TIME = 4 MINUTES | |
| 05 | SOUNDER DELAY TIME = 5 MINUTES | |
| 06 | SOUNDER DELAY TIME = 6 MINUTES | |
| 07 | SOUNDER DELAY TIME = 7 MINUTES | |
| 08 | SOUNDER DELAY TIME = 8 MINUTES | |
| 09 | SOUNDER DELAY TIME = 9 MINUTES | |
| 10 | COMMON ALARM MODE (default) | All sounders operate upon any alarm condition |
| 11 | TWO-STAGE ALARM MODE | Continuous sounders in activated zone, pulsing elsewhere |
| 12 | ZONED ALARM MODE | Only sounders connected to zone in alarm operate |
| 21* | DISABLE ALARM BUZZER | Buzzer will not operate on alarm condition |
| 22* | DISABLE FAULT OUTPUT | Fault relay will not operate except upon total power failure |
| 23 | DISABLE EARTH FAULT MONITORING | Connection of alarm wiring will not announce a fault |
| 24 | PULSED REMOTE CONTROL OUTPUT | Aux 24V supply pulses 1 sec on/1 sec off |
| 25 | ENABLE SOUNDERS ON DETECTION CIRCUITS | Set if using sounder extension boards |
| 26 | DISABLE ALARM OUTPUT | Alarm relay will not operate upon any alarm |
| 27 | REMOVE AUX 24 UPON PANEL RESET | 24V supply switches off for about 5 seconds when panel is reset |
| 28 | NOT USED | |
| 29 | DO NOT RE-SOUND ALARMS FROM ANOTHER ZONE | Silenced sounders will not re-sound upon further zone activations |
| 31 | ZONE 1 ALARM FROM DETECTOR DELAYED | Sounder outputs will be delayed by time set at options 0-9 when selected zone(s) triggered by detector only. Note: Access level 2 function Ad must be set for this to take effect. |
| 32 | ZONE 2 ALARM FROM DETECTOR DELAYED | |
| 33 | ZONE 3 ALARM FROM DETECTOR DELAYED | |
| 34 | ZONE 4 ALARM FROM DETECTOR DELAYED | |
| 35 | ZONE 5 ALARM FROM DETECTOR DELAYED | |
| 36 | ZONE 6 ALARM FROM DETECTOR DELAYED | |
| 37 | ZONE 7 ALARM FROM DETECTOR DELAYED | |
| 38 | ZONE 8 ALARM FROM DETECTOR DELAYED | |
| 51 | COINCIDENCE ZONE 1 | Zone contributes to ancillary board coincidence O/P. Any number of zones can be selected to contribute. |
| 52 | COINCIDENCE ZONE 2 | |
| 53 | COINCIDENCE ZONE 3 | |
| 54 | COINCIDENCE ZONE 4 | |
| 55 | COINCIDENCE ZONE 5 | |
| 56 | COINCIDENCE ZONE 6 | |
| 57 | COINCIDENCE ZONE 7 | |
| 58 | COINCIDENCE ZONE 8 | |
| CODE | FUNCTION | COMMENTS |
| 71* | ZONE 1 SHORT CIRCUIT INDICATES ALARM | Changes the trigger threshold of the zone so that the control panel can be used on older systems that had no short circuit monitoring. |
| 72* | ZONE 2 SHORT CIRCUIT INDICATES ALARM | |
| 73* | ZONE 3 SHORT CIRCUIT INDICATES ALARM | |
| 74* | ZONE 4 SHORT CIRCUIT INDICATES ALARM | |
| 75* | ZONE 5 SHORT CIRCUIT INDICATES ALARM | |
| 76* | ZONE 6 SHORT CIRCUIT INDICATES ALARM | |
| 77* | ZONE 7 SHORT CIRCUIT INDICATES ALARM | |
| 78* | ZONE 8 SHORT CIRCUIT INDICATES ALARM | |
| 81* | ZONE 1 NON-LATCHING | Renders the zone self-resetting so that it can be used to receive signals from other systems and will reset when the input is removed. Note: It can take up to 20 seconds for zone to reset itself when sounders are operating |
| 82* | ZONE 2 NON-LATCHING | |
| 83* | ZONE 3 NON-LATCHING | |
| 84* | ZONE 4 NON-LATCHING | |
| 85* | ZONE 5 NON-LATCHING | |
| 86* | ZONE 6 NON-LATCHING | |
| 87* | ZONE 7 NON-LATCHING | |
| 88* | ZONE 8 NON-LATCHING | |
| 91 | ZONE 1 DOES NOT SOUND ALARMS | Prevents the zone from operating the two common sounder outputs. |
| 92 | ZONE 2 DOES NOT SOUND ALARMS | |
| 93 | ZONE 3 DOES NOT SOUND ALARMS | |
| 94 | ZONE 4 DOES NOT SOUND ALARMS | |
| 95 | ZONE 5 DOES NOT SOUND ALARMS | |
| 96 | ZONE 6 DOES NOT SOUND ALARMS | |
| 97 | ZONE 7 DOES NOT SOUND ALARMS | |
| 98 | ZONE 8 DOES NOT SOUND ALARMS | |

| | | |
|-----|-------------------------------------|--|
| A1* | ZONE 1 ANY ALARM DELAYED | Zone needs to be triggered for 30 seconds continuously before an alarm is generated. |
| A2* | ZONE 2 ANY ALARM DELAYED | |
| A3* | ZONE 3 ANY ALARM DELAYED | |
| A4* | ZONE 4 ANY ALARM DELAYED | |
| A5* | ZONE 5 ANY ALARM DELAYED | |
| A6* | ZONE 6 ANY ALARM DELAYED | |
| A7* | ZONE 7 ANY ALARM DELAYED | |
| A8* | ZONE 8 ANY ALARM DELAYED | |
| C1 | ZONE 1 SOUNDERS INHIBITED | Enables individual zones to be configured not to operate zonal sounders. On 2 wire "T" series panels this enables individual zones to be configured for use with conventional (non 2-wire) detector bases. SOFTWARE VERSIONS SIGMA242.HEX and above only |
| C2 | ZONE 2 SOUNDERS INHIBITED | |
| C3 | ZONE 3 SOUNDERS INHIBITED | |
| C4 | ZONE 4 SOUNDERS INHIBITED | |
| C5 | ZONE 5 SOUNDERS INHIBITED | |
| C6 | ZONE 6 SOUNDERS INHIBITED | |
| C7 | ZONE 7 SOUNDERS INHIBITED | |
| C8 | ZONE 8 SOUNDERS INHIBITED | |
| E1* | ZONE 1 WILL NOT OPERATE ALARM RELAY | Enables individual zones to be selected to not operate the alarm relay. This is sometimes combined with the non-latching function to prevent ring around on interconnected panels. |
| E2* | ZONE 1 WILL NOT OPERATE ALARM RELAY | |
| E3* | ZONE 1 WILL NOT OPERATE ALARM RELAY | |
| E4* | ZONE 1 WILL NOT OPERATE ALARM RELAY | |
| E5* | ZONE 1 WILL NOT OPERATE ALARM RELAY | |
| E6* | ZONE 1 WILL NOT OPERATE ALARM RELAY | |
| E7* | ZONE 1 WILL NOT OPERATE ALARM RELAY | |
| E8* | ZONE 1 WILL NOT OPERATE ALARM RELAY | |

Once the required configuration options have been set, the Write enable switch **must** be returned to its normal position to the right. The General fault indicator will remain lit if the Write enable switch is not turned off.

16. Watchdog reset switch

If for any reason the microprocessor in the control panel fails to carry out its operation correctly it will attempt to restart itself. This process is called a "watchdog" and the control panel must record and indicate these events.

If a watchdog event occurs, the control panel will show the FAULT and SYSTEM FAULT LEDs on the front panel, the CPU fault LED inside the panel.

This fault can only be cleared by pressing the WATCHDOG RESET button on the PCB inside the control panel. The control panel buzzer can not be silenced and will continue to sound until the watchdog activation is reset.

17. Processor reset switch

Once started, the microprocessor controlling the panel should continue to run continuously without interruption. If the microprocessor fails to run correctly it can be reset by pressing the PROCESSOR RESET button on the PCB inside the control panel.

This should not normally be necessary but should be done as a matter of course if the system is behaving abnormally. The system should resume normal operation within a couple of seconds of pressing the processor reset button.

18. Internal indications – troubleshooting

To assist in identifying fault conditions which are not detailed on the front of the control panel, a number of internal indicators are visible with the front cover removed as follows:

18.1 Mains fail

Indicates that the 230V AC supply is not present and the system is running on standby batteries. If there is not a power cut, check the panels mains fuse.

18.2 Batt fail

Indicates that the standby battery has become disconnected or that the charging circuit of the control panel has a high resistance or has failed. Check that both batteries are connected and linked together. Test battery. Disconnect battery and ensure that 28 Volts can be measured on battery charger leads.

18.3 CPU fault

Indicates that the central processor unit has failed to correctly execute code and has been re-started by the system watchdog. The watchdog reset switch must be pressed to clear the CPU fault condition.

Press watchdog reset. If system does not return to normal then the panel is probably damaged and needs the circuit board replacing. (See maintenance section).

18.4 Aux 24V fault

The Aux 24V and R0V terminals provide a 500 milliamp, 24V DC power supply for power alarm ancillary equipment. This LED indicates that fuse protecting the R0V output has operated and the rating of this output has been exceeded. The fuse is a self resetting type and the supply will resume when the fault condition is removed.

18.5 Batt low

Illuminates when the system is running on batteries and the battery voltage is lower than 21V +/-2% (the minimum battery voltage).

18.6 Earth fault

Indicates that part of the system wiring is connected to earth. Remove all system wiring and re-connect cables one at a time until the earth fault returns. This will indicate which cable the earth fault is present on.

18.7 Sys fuse fault

Indicates that the total power rating of the power supply has been exceeded and that the system fuse has come into operation. Remove and review all loads and re-connect one at a time until over rated circuit trips fuse to identify troublesome circuit.

18.8 S1 fault and S2 fault

Indicates a short or open circuit on sounder outputs. Remove wiring and refit end of line resistors. Check sounder circuit wiring.

18.9 Comms fault

Indicates that communication has been lost with a repeater panel or Ancillary board. Check for comms fault at all repeaters and ancillary boards to identify the source of the problem.

19. Power supply

The control panel requires a 230V (+10%/-15%), 50/60Hz, AC mains power supply which connects to the fused terminal block labelled "230V".

The fused terminal block contains a 20mm, F1.6A L250V fuse which should only be replaced with a similar type.

The output voltage of the power supply is 28V DC +/- 2V and the total current rating including a maximum 0.7A for battery charging is 3 Amps. Fuse F12 mounted on the circuit board is a self-resetting electronic fuse rated at 4 Amps.

The incoming mains cable should be routed well away from other lower voltage wiring by a distance of at least 50mm.

Mains wiring should include an earth conductor which is securely bonded to the building earth and should enter the enclosure as close as possible to the mains terminal block. Mains wires should be kept very short inside the enclosure and secured together close to the mains terminal block with a cable tie.

The control panel can accept sealed lead acid rechargeable batteries of up to 7Ah maximum capacity (see table 2 for battery size required for each model).

The maximum current drawn from the batteries when the main power source is disconnected is 3 Amps.

Battery leads are supplied wired to the PCB along with a link to connect the two batteries in series. The PCB is fitted with a 20mm, 3.15A T1 glass fuse (F13) in the battery charging circuit which must only be replaced with one of the same type.

It is most important that the polarity of the batteries is carefully observed when connecting.

When the batteries are discharged to a level at which a low battery indication is given, the BATT FAIL indicator will also be lit.

Wrongly connected batteries could cause damage to the control panel.

Figure 9 – Mains and battery connections

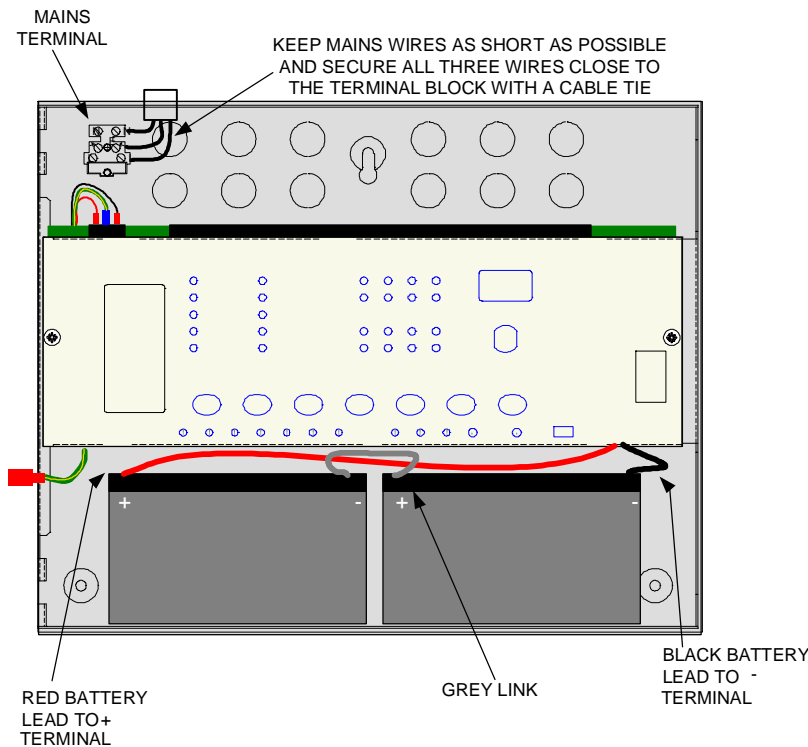

20. Maintenance

HYDROSENSE HSCP control panels do not require any specific maintenance but should the control panel become dirty it can be wiped over with a damp cloth and should then be dried with a dry, lint free cloth. Detergents or solvents should not be used to clean the panel and care must be taken that water does not enter the enclosure.

The control panel contains sealed lead acid batteries to provide standby power in the event of a mains failure.

These batteries have a life expectancy of around 4 years. It is recommended that these batteries be tested in accordance with the battery manufacturer's recommendations annually to determine their suitability for continued standby applications.

Routine testing of the Hydrosense Water Detection System will identify any malfunction of the control panel and any malfunction should be reported to the alarm maintenance company immediately.

Should the control panel become faulty the complete electronic assembly can be replaced.

To do this, any configured options should be noted then both mains and battery power should be removed before the work is started.

The field wiring should be carefully labelled and removed from the terminals.

The PCB can now be taken out of the panel by removing the 2 holding the plate in position. Fitting the new PCB is the reverse of the procedure for removing the board.

21. Zone designation label

All HYDROSENSE HSCP control panels are supplied with a zone designation label onto which zone designations can be written.

This enables each zone to be given a text description allowing easier identification of any zones showing an abnormal condition.

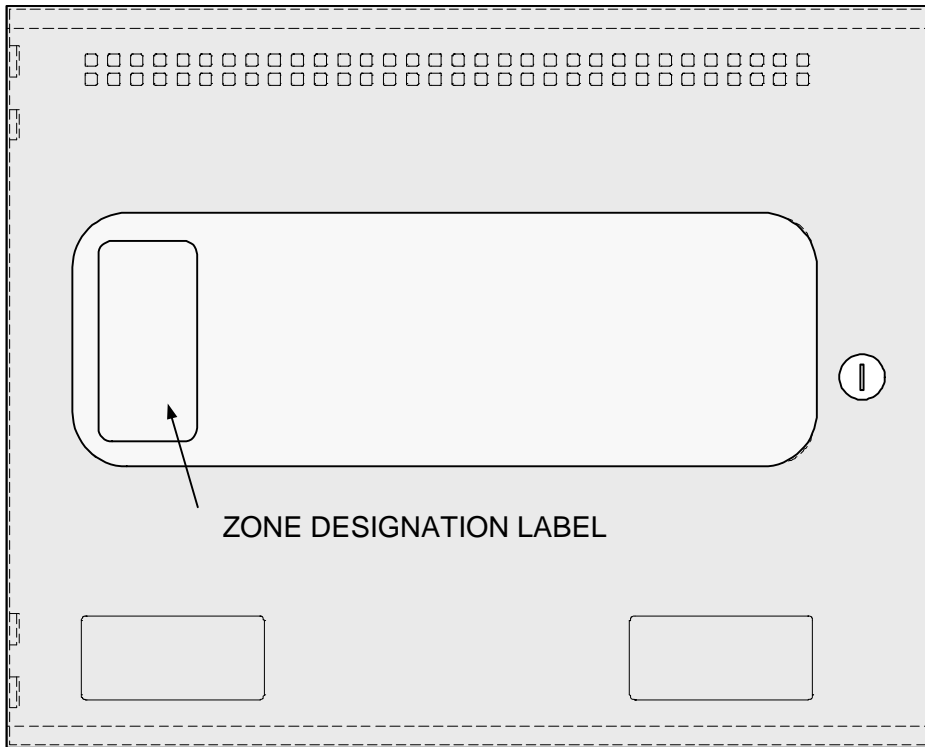

22. Hydrowire commissioning details

22.1 Installation

22.1.1 Lengths of Hydrowire should be laid on the floor in the protected area such that the distance between any two Hydrowires is no more than 2 metres.

22.1.2 For localised protection of sources of potential water leakage, such as air conditioning systems or water filled radiators, the distance between Hydrowires may be greater.

22.1.3 The cable should be installed such that it remains in contact with the floor along as much of its length as possible. This may require the use of P clips, particularly in areas where the cable may be disturbed.

22.1.4 Although the construction is quite sturdy, the cable may be damaged by crushing or excessive bending. A bend radius of 150 mm is recommended as a minimum.

22.1.5 The end of the Hydrowire must be terminated with an end of line plug (K2110).

22.1.6 The terminating connection box (K2106) should be secured to the wall or floor such that the Hydrowire does not have to be stretched or pulled to reach it.

22.1.7 The installed Hydrowire should consist of a K2106 connection box, Hydrowire cable (K2104 or/and K2105) and end of line plug unit (K2110).

22.1.8 The red warning label should be left such that it is clearly visible.

22.1.9 Hydrowire should not come into contact with surface temperatures greater than 70°C.

22.1.10 Lengths greater than 50 metres are not allowed.

22.2 Connection to Control Panel

22.2.1 The K1622 connection box, when triggered presents an impedance of 470 R to the 24 volt circuit from the control panel.

22.2.2 The + and - terminals inside the connection box must be connected to the Z+ and Z terminals at the control panel.

22.2.3 The end of line resistors at the control panel should be discarded.

22.2.4 It is advisable to leave off the lid of the connection box, until all testing is complete.

22.3 Remote Lamp Connection

22.3.1 In some installations, particularly in floor voids, it is desirable to identify the area in which water has been detected, with a remote indicator unit mounted above the void.

22.3.2 This can be achieved by wiring a K2103 remote lamp unit to the - and rem. terminals in the K2106 connection box.

22.3.3 Only one remote lamp unit should be connected to each connection box.

22.4 Testing

22.4.1 Once all terminations have been made and the system is powered, the Hydrowire is ready for testing.

22.4.2 Testing is best done by dipping the thumb and forefinger into a cup of tap water, shaking off the excess drips and then gripping the Hydrowire firmly whilst rolling it slowly. This should produce an immediate indication at the control panel.

22.4.3 Over wetting the Hydrowire should be avoided as a great deal of time can be wasted by waiting for it to dry out.

22.5 General Checklist

22.5.1 Avoid excessive wetting.

22.5.2 Observe polarity of all connections.

22.5.3 Long lengths of Hydrowire may be susceptible to high levels of electrical noise. Keep lengths short wherever possible and do not install close to other cables.

22.5.4 Do not twist, bend sharply, stretch, stand on or crush the Hydrowire.

22.5.5 Do not expose to surface temperatures above 70°C.

22.5.6 Use only recommended Hydrowire system components.

23. Hydrosense Probe Commissioning

This is best achieved by dipping the tips of the probe pins into a cup of tap water.

This should produce an immediate reaction at the control panel, the LED mounted on top of the probe and, if fitted, the remote lamp unit and or sounder.