

# Xenon Strobe Beacons

The comprehensive range of high efficiency xenon beacons offers high light output with custom built attachments for the Hosiden Besson Banshee and Bedlam range of electronic sounders.

Used alone, the xenon beacons are ideal where bold visual indication is required. Mounting with the custom built attachment allows the strobe and sounder to become one.



## Features

- Four power ratings - 1,2,3 & 5 watt
- Flash rate of 60 per minute
- Operates on 12 or 24 Vdc
- Rated at IP65 as standard
- Weatherproof version available with enclosed terminals
- Combination bracket for strobe and sounder
- Hard wearing polycarbonate lenses with different colour options
- Easy to install



## Specification

Power Rating	1 watt	2 watt	3 watt	5 watt	1 watt	2 watt
Enclosure	Standard	Standard	Standard	Standard	Weatherproof	Weatherproof
Part No. - Red Lens	2003300	2003900	2003000	2003800	2001000	2000900
- Amber Lens	2003400	2003700	2002900	2004100		2002800
- Blue Lens		2002500				
- Clear Lens		2001400				
Dimensions (w x h mm)	75 x 51	75 x 51	75 x 51	75 x 90	83 x 103	83 x 103
Nom. Voltage ( $\pm 10\%$ )	12 or 24Vdc					
Nom. Current mA (@12/24Vdc)	84/42	168/84	252/126	420/210	84/42	168/84
Flash Rate	60 per minute					
Operating Temperature Range	-30°C to +70°C					
IP Rating	65					

## Installation

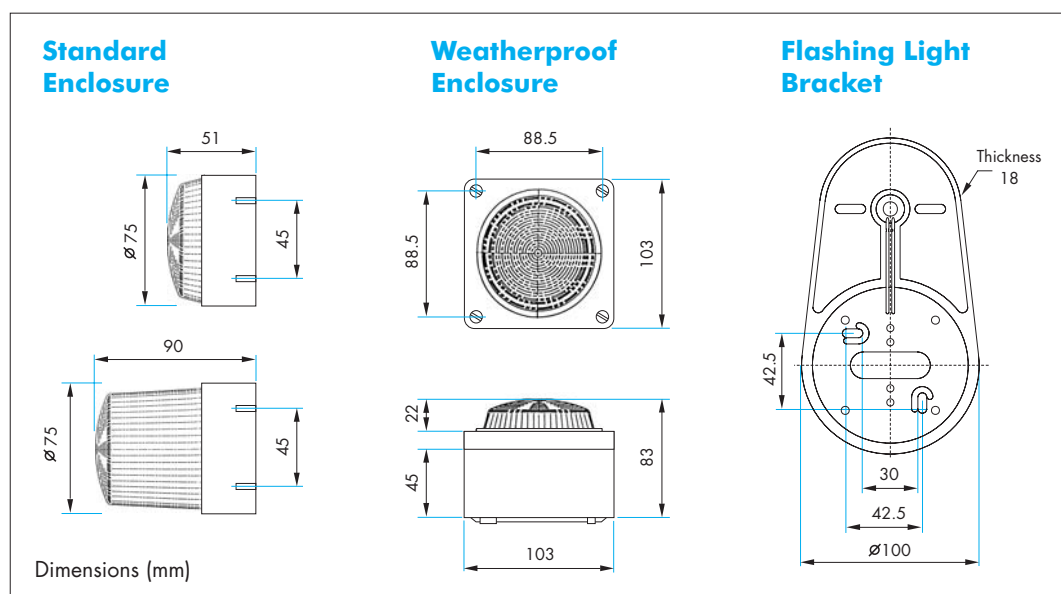

**VIMPEX**

### Vimpex Ltd

Star Lane, Great Wakering  
Essex, SS3 0PJ England.  
Tel: +44 (0) 1702 216999  
Fax: +44 (0) 1702 216699  
E-mail: sales@vimpex.co.uk

[www.vimpex.co.uk](http://www.vimpex.co.uk)



Quality System Certificate No. 456  
Assessed to ISO 9001:2000



We reserve the right to change or amend any design or specification in line with our policy of continuing development and improvement.

Part No: DS/XNON/ISS 6

## Other Products and Accessories



- Fire-Cryer® Voice Enhanced Sounders
- Electronic Sounders
- Fire Alarm Bells
- Sounder Accessories & Fire System Ancillaries
- Stopper Range of Vandal Deterrent Products
- Water Leakage Detection Systems