

VIMPEX

Shaping Alarm Technology

Overview of the Hydrosense Water Detection System	2
Linear Detection	3
Point Detection	3
Components of a Hydrosense System	4
Hydrosense Mimic Panels	5
Design & Planning	7
Design Guidelines	8
System Installation Notes	9
Hydrowire Installation and Commissioning	10
Hydrowire Commissioning – HSHWC-100	11
Floor Probe or Drip Tray Probe Installation HSFPI -100	12
Floor or Drip Tray Probe Testing	12
Floor or Drip Tray Probe Testing	13
Hydrowire Connection Box	14
Remote Lamp Connection	14
Hydrosense Commissioning Record	15
Hydrowire Layout	17
Probe Layout	18
CONSULTANTS SPECIFICATION FOR WATER LEAK DETECTION	19

Vimpex Limited

Star Lane

Great Wakering

Essex SS3 0PJ

Tel: +44 (0) 1702 216999 – Fax +44 (0) 1702 216699

email: sales@vimpex.co.uk web: www.vimpex.co.uk

Overview of the Hydrosense Water Detection System



The Hydrosense water detection system is designed to detect the intrusion of water in concealed areas or any place where water penetration must be identified so that corrective action can be taken immediately.

It will continuously monitor the potential hazards 24 hours a day and has the facility for 24 hours battery standby in the event of power failures.

Any water penetration detected will be signalled to a control panel that can give audible and visual alarms.

The detection system comprises of three basic components, water detection cable, localised probes and a control panel.

Water leak detection systems can be divided into two basic categories:

- (a) Linear Detection
- (b) Point Detection

The Hydrosense System incorporates both.

Linear Detection

Where floor areas, ducts and suspended ceilings need to be protected this is usually best achieved by installing lengths of Hydrowire.



Hydrowire is a highly conductive cable extremely sensitive to moisture. It is available in 5 metre lengths (K2104) or 10 metre lengths (K2105). Each length of Hydrowire is terminated with a male and female din plug to enable them to be plugged together up to maximum zone length of 50 metres. As soon as the cable detects moisture this will trigger an alarm.



Each zone of Hydrowire is plugged into a Connection Box (K2106) and terminated by an End of Line Plug (K2110) which enables it to be continuously monitored for defects.

The connection box is then connected to the control panel using 0.75mm² 2 core cable (K2112).



Up to 48 zones can be incorporated on one panel.

Point Detection



Floor Probe

Where there is a need for more localised detection such as HVAC plant, drip trays, elevator shafts and storage areas a probe can be installed and adjusted to the required level of protection.

As with the cable the detection of moisture triggers an alarm and is also monitored by the line fault circuit of the control panel. Additionally the probe has an LED indicator on top to identify exactly which probe has been activated. Up to 20 detectors can be used in each zone.

Components of a Hydrosense System

This guide will help to select products from the Hydrosense range for water detection in a variety of applications.

Basic Components

Control Panel (2 to 48 Zones)

There are two types of control panel available:

- a) **HSCP Series** – This panel is available in 2, 4 and 8 zone configurations. These are fully programmable and allow the addition of Ancillary PCBs, repeater panels and a Mimic Display.



Ancillary PCBs provide a means to extend Alarm, Fault, coincidence and zonal alarm volt free contacts to locations remote from the control panel via a 2 core data bus.



- b) **K2000 Series** – The K2000 panel is available in 12, 16, 24 and 48 zones as standard. Larger configurations are also available. zonal alarm and repeat contacts as standard. This panel can also be supplied as a flush mounted version and with special finishes. Repeater panels are also available.

Hydrosense Mimic Panels

The Hydrosense Mimic Display uses flexible fibre optic guides to illuminate areas on a floor plan. This provides a clear, geographical indication of the alarm activation enabling a speedy identification of the source and location of the alarm.

This unique system dispenses completely with wiring and enables indicators to be moved, removed or added without the need for any wiring.

It can only be used with the HSCP range of panels.

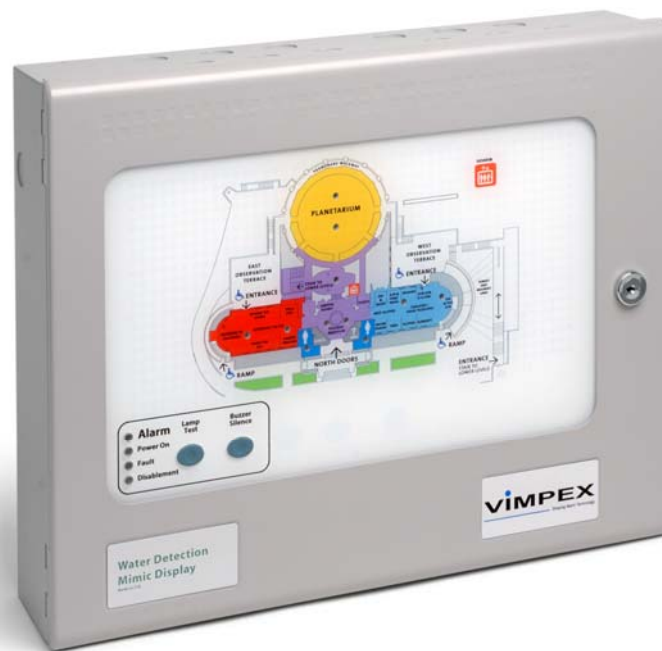

The following components are common to both panels:

Hydrowire (5 metre Length)	K2104
Hydrowire (10 metre Length)	K2105
End of Line Plug	K2110
Hydrowire Connection Box	K2106
Leader Cable	K2111
Hydrowire / Leader Cable Fixing Clips	K2112
Batteries K1220	

Options

Floor Mounted Probe	K2101
Drip Tray Probe	K2102
Remote Lamp Unit	K2103
Strobe Light	SL-401-24-B
Voice Sounder	F/A/1W
White Sounder (Multi Tone)	892A4A0
FlashTone - Combined white sounder and blue strobe	8581800

Design & Planning

Design Notes

- ✚ Water finds its own level so careful consideration must be given to slopes and dips in the area to be protected.
- ✚ Can the cable be installed to avoid doorways and traffic.
- ✚ Floor probes can be used to protect wells, cavities or hollows.
- ✚ Is the site occupied? If so, will the site require just visible alarms or will there be a need for conventional or voice enhanced sounders?
- ✚ Is a remote signalling device required?
- ✚ How is the cable to be fixed to the floor? Are other services going to interfere with it?
- ✚ Check with the building owner or manager for future plans or designs that may alter the requirements or siting of the equipment.
- ✚ Will the system require expansion? Give consideration to the possible addition of extra zones.
- ✚ Maximum length of Hydrosense cable should be kept to 50 metres
- ✚ Maximum number of detectors per zone should not exceed 20.
- ✚ Only one remote indicator to each Hydrowire Connection Box.

Design Guidelines

Hydrosense Probe:

Maximum recommended coverage:	-	20 sq.m per detector
Maximum recommended detectors per zone	-	20
Maximum distance between probes for perimeter detection	-	3 metres
Sensor height above finished floor	-	1mm to 15mm
Leader cable	-	0.75mm round 3A

Hydrowire Cable:

Maximum recommended length per zone	-	50 metres
Recommended pitch between cable for area protection	-	2 metres
Minimum bend radius	-	150mm

Note: Do not mix probes and Hydrowire on the same zone

System Installation Notes

1. Check design with the kit and components in hand to check that all materials are on site. Check the BOM.
2. Store Hydrowire lengths carefully in a dry area.
3. Prepare the installation area. Remove any furniture or equipment that may obstruct installation. Make sure the area is clean and free from debris.
4. Install and commission the Control Panel in accordance with the appropriate Control Panel installation manual
5. Install the Hydrowire in accordance with the installation procedure HSHWI-100
6. Commission the Hydrowire in accordance with the test procedure HSHWC-100
7. Install and test any floor probes in accordance with the appropriate test procedure HSFPI-100
8. Test the complete system
9. Commission
10. Train the owner / operator

Hydrowire Installation and Commissioning

HYDROWIRE INSTALLATION HSHWI-100

- (1) Check the length of cable for fraying or damage.
- (2) Connect the lengths of Hydrowire to be used in the zone and terminate with an End of Line Plug (K2110). Temporarily connect the cable to the control panel via a Hydrowire Connection Box (K2106). Check that no fault or alarm is reported.



**Connection Box
K2106**



**End of Line
Plug K2110**

- (3) Remove the end of line plug and check that an alarm is reported.
- (4) Disconnect the Hydrowire and store ready for installation.
- (5) Ensure that the installation area is clean and free from water, dust and debris.
- (6) Lay the length of Hydrowire on the floor of the area to be protected so that the distance between any two Hydrowires is no more than 2 metres. (For localised protection of sources of potential water leakage, such as air conditioning and water filled radiators, the distance between Hydrowires may be greater).
- (7) The cable should be installed so that it remains in contact with the floor for as much of its length as is possible. This would usually require the use of Hydrowire fixing clips (K2112). *Great care must be taken when using other fixing clips. Although the cable is quite sturdy it can be damaged by crushing or excessive bending. A bend radius of 150mm is recommended as a minimum.*
- (8) The terminating Hydrowire Connection Box (K2106) should be secured to the wall or floor such that the Hydrowire does not have to be stretched or pulled to reach it.

- (9) Plug the cable into the Hydrowire Connection Box (K2106).
- (10) The red warning label should be left such that it is clearly visible.
- (11) Terminate the cable with an end of line plug (K2110).

Notes : **Hydrowire should not come into contact with surface temperatures greater than 70° C.**

Lengths greater than 50 metres are not permissible.

Hydrowire Commissioning – HSHWC-100

Once all terminations have been made and the system is powered, the Hydrowire is ready for testing.

This is best achieved by dipping the forefinger and thumb into a cup of tap water, shaking off the excess drips and then gripping the Hydrowire firmly whilst rolling it slowly.

This should produce a reaction at the control panel and if fitted, the remote lamp unit and or sounder.

Over-wetting of the Hydrowire should be avoided as a great deal of time can be wasted waiting for the Hydrowire to dry out. **DO NOT MIX PROBES AND HYDROWIRE IN THE SAME ZONE.**

It is advisable to test all lengths of Hydrowire before fixing into place so that should a fault be found it can easily be replaced.

Floor Probe or Drip Tray Probe Installation HSFPI -100

The floor probe is connected to the control panel via a junction box (See Fig. 11). **Note:** The 6K8 resistor taken from the zone being used in the control panel must be installed as shown in Fig. 1 with the last Probe in the zone (maximum of 20 probes per zone.)

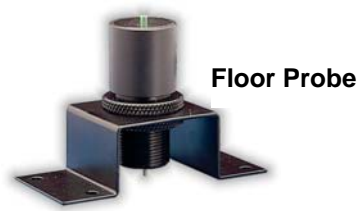

Both the drip tray probe and the floor probe are supplied with 1 metre of 4 core cable with a pre-fitted din plug. This is plugged into the head of the probe and the 4 core cable terminated in a junction box. See Fig 1.

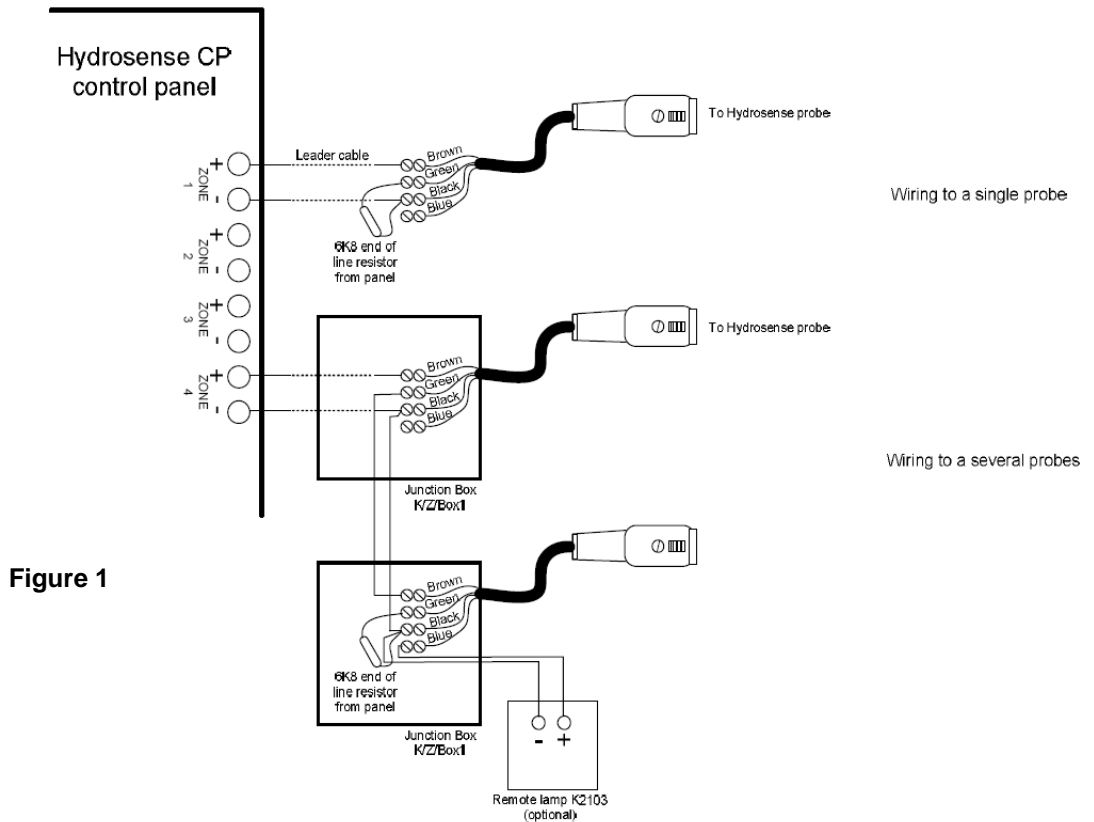

Floor or Drip Tray Probe Testing

- (1) This is best achieved by dipping the tips of the probe pins into a cup of tap water.

- (2) This should produce an immediate reaction at the control panel, the LED mounted on top of the probe and, if fitted, the remote lamp unit and or sounder.

Hydrowire Connection Box

The K2106 Connection Box, when triggered presents an impedance of 470 ohms to the 24 Volt circuit from the control panel.

Hydrowire Connection Box

The + and – terminals inside the Connection Box must be connected via a 2 wire 0.75mm round 3A cable to the Z+ and Z- terminals at the control panel.



Figure 2

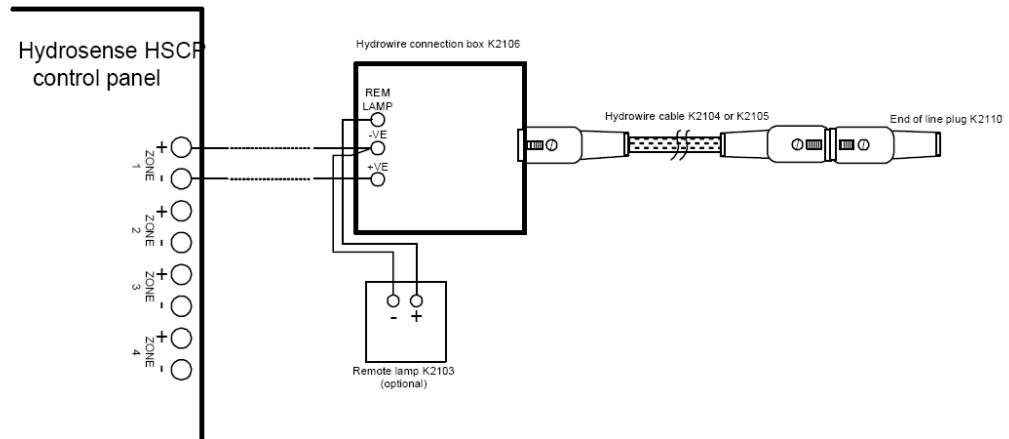

The end of line resistor at the control panel can be discarded. It is advisable to leave the lid off the control panel until all testing is complete.

Remote Lamp Connection

In some installations, particularly in floor voids, it is desirable to identify the area in which water has been detected with a remote indicator unit (K2103) mounted above the void.

This can be achieved by wiring a K2103 remote lamp unit to the –ve and REM terminals in the K2106 Connection Box.

Note : Only one remote lamp unit should be connected to each Connection box.

Hydrosense Commissioning Record

Customer / Site
Address

Town / City

Post Code

Site Tel No.

Site Contact Name

Control Panel Type

No. of Hydrowire
Zones

No. of Probe Zones

Authorised Engineer

Company

Tel No.

Date

1. Control Panel

- Control panel is connected via a dedicated power supply
- Green Supply Healthy lamp illuminated. No other lamps illuminated
- Internal buzzer operates when enable key is inserted
- Reset test switch illuminates all lamps
- Alarm Test Switch operates the internal buzzer

2. Hydrowire

- Installed
- Not Installed
- Hydrowire checked for damage
- Hydrowire wetted and checked for correct zone alarm
- End of Line Plug removed and checked for correct zone fault
- Check correct clips installed and not crushing or over bending Hydrowire
- Red warning labels are in place

Hydrosense Commissioning Record

3. Connection Boxes

- Installed
- Not Installed
- Fixed securely
- Wiring terminated correctly

4. Floor and Drip Tray Probes

- Installed
- Not Installed
- Din plug disconnected from probe and checked for correct zone fault
- Probe conductor pins set at correct height
- Probe pins immersed in water and checked for correct zone alarm
- Probe terminated correctly into junction box

The above commissioning record has been completed by :

Authorised Engineer

Print Name

Company

Tel No.

Date

The above commissioning record has been accepted by :

Authorised Representative

Print Name

Company

Tel No.

Date

Figure 3

Hydrosense

Hydrowire Layout

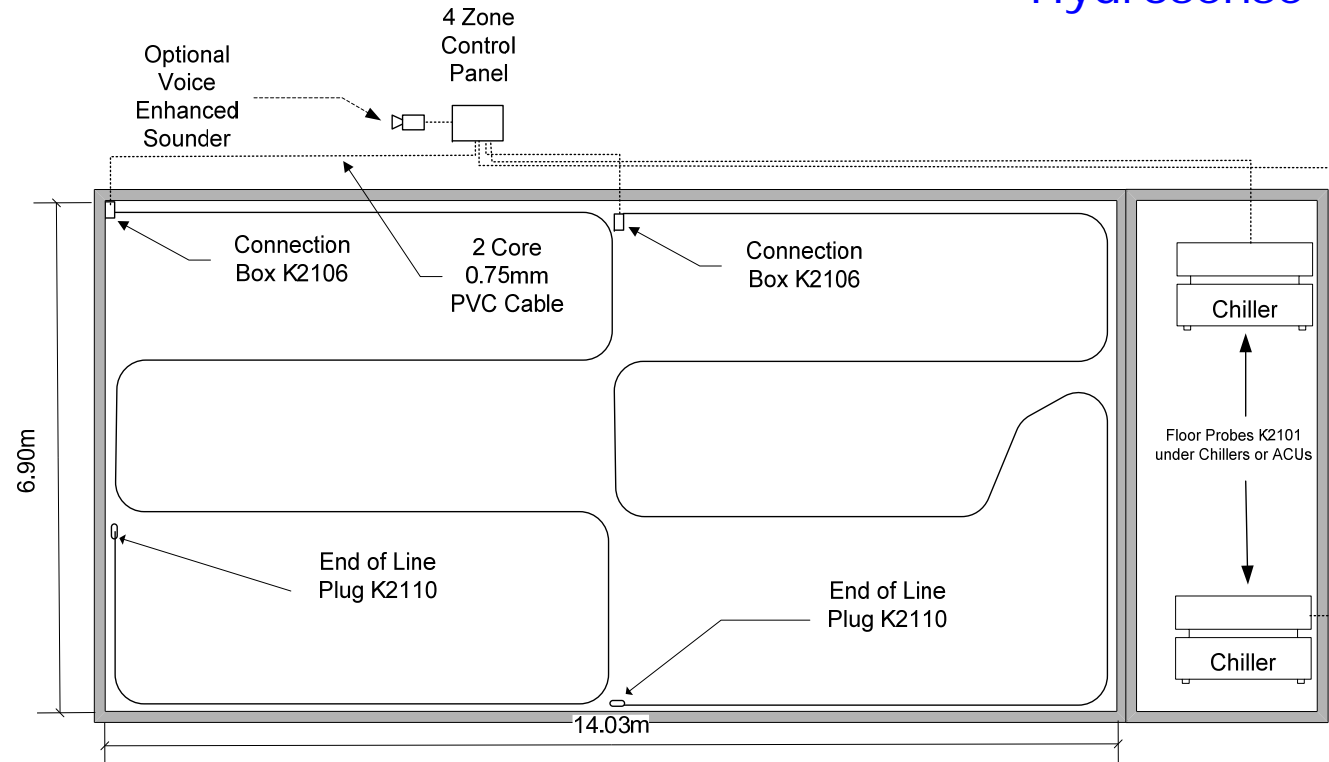

Part Ref	Description	Qty
HSCP-S-4	4 HSCP Panel	1
K2105	Hydrowire 10M Length	8
K2110	End of Line Plug	2
K2106	Connection Box	2
K2112	Pack of Fixing Clips	3
K2101	Floor Mounted Probe	2
K/Z/Box1	ABS Junction Box for Probes	2
*PS1270	12V 2.0ah Battery	2
*K2111	Leader Cable (50M 2 core 0.75mm 3A)	1
**F/A/1/BH	Voice Enhanced Sounder	1

Figure 4

Probe Layout

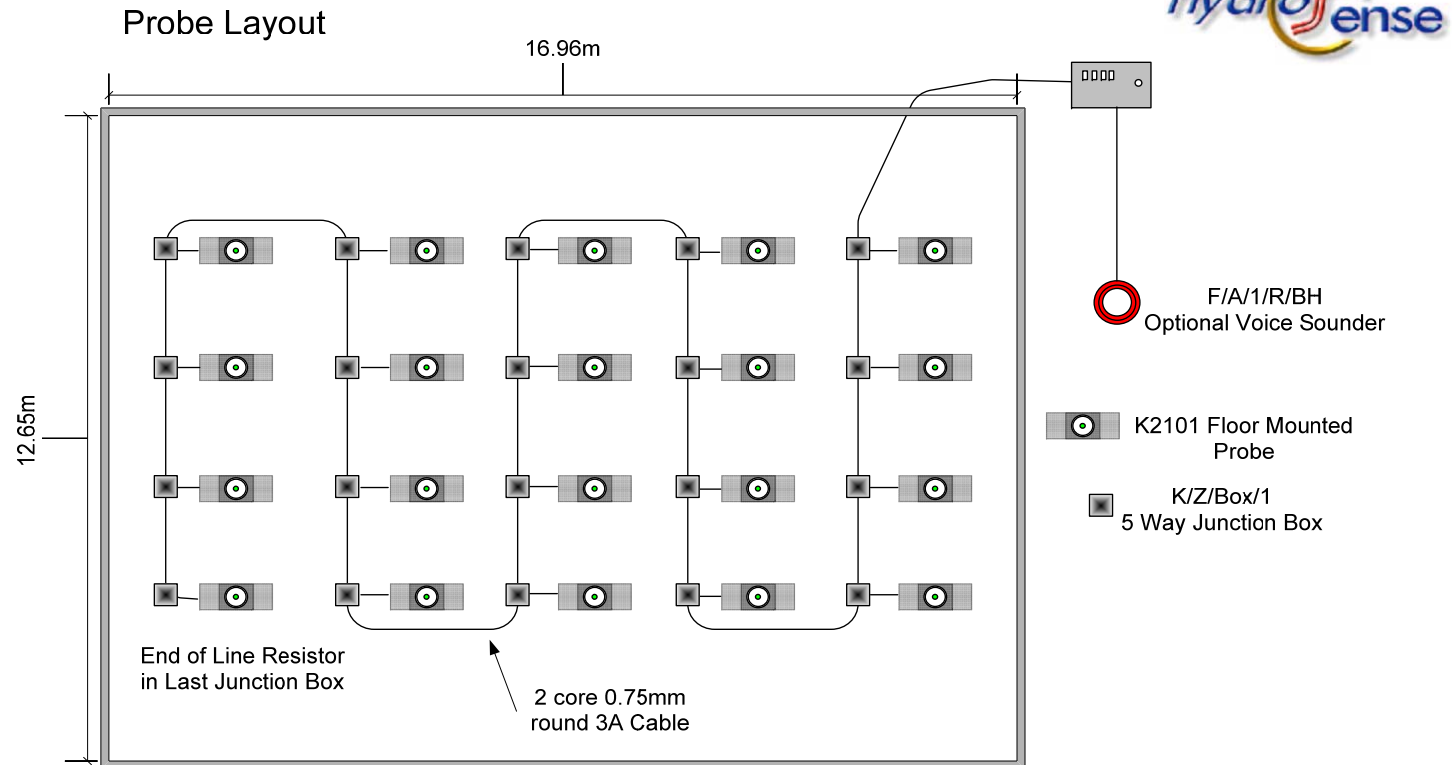

CONSULTANTS SPECIFICATION FOR WATER LEAK DETECTION

The water detection system should be able to detect the intrusion of water in concealed areas or any place where water penetration must be identified so that corrective action can be taken immediately.

It will continuously monitor the potential hazards 24 hours a day and has the facility for 24 hours battery standby in the event of power failures.

Any water penetration detected will be signalled to a control panel that can give audible and visual alarms.

The detection system will be able to provide linear detection using water detection cable and point detection using localised probes and a control panel.

The water detection cable must be reusable after detecting moisture and be monitored for fault at all times.

Additionally the probe will incorporate an LED indicator to identify exactly which probe has been activated. Up to 20 detectors should be able to be connected to a single zone. Sensor height should be adjustable from 1mm to 30mm from above finished floor. The probe shall be monitored for faults at all times and shall be of the latching type.

The Control Panels will be available as a single zone panel as well as multi zones up to a minimum of 48 zones.

The control panel will provide Fault Volt-Free Contacts and Alarm Volt-Free Contacts for remote signaling or plant shutdown on the occurrence of any fault or alarm condition.